



Gobius 1, 3/4 Level Alarm for Waste Holding Tanks

Installation Guide

Before you begin

1. Please make sure that no part is missing. (1 sensor, 1 panel, 1 control unit (091427), 1 3M cleaning towel, 1 Velcro fastening for the control unit, 3 cables, 1 spare VHB tape, warranty statement and installation instruction on how to attach the sensors.
2. Determine the best place on your tank to place the sensor and where to place the panel.
3. Determine the best way to safely access electricity from your 12/24 Volts battery.

Quick installation

- Attach the sensor to the tank
- Connect all parts
- Start Gobius
- Change the default settings
- Calibrate when the tank is empty
- Control the new settings
- Test and run Gobius
- Plug in to external instrument , lamp or buzzer

Installing the panel and connecting the system

1. Decide where to place the Gobius panel. It can for instance be installed in your head/shower or near your waste holding tank. You may increase the length of the panel cable up to 50 m with a standard PC network Cat 5 cable. We can supply 10 meter cables.
2. We suggest that you make a small rectangle hole where you want to place the cable from the panel to the control unit. The hole should be at least 4 mm x 22 mm. Please see the enclosed hole template at page 5.
3. Use the pre-attached adhesive to fasten the panel to the wall.
4. Connect the panel and the sensor to the control unit. Then connect the cables to the battery. Make sure to connect + and – correctly to the battery (+ is white and – is black), as also described on the control unit. Please see the illustration at page 5.
5. If you want to connect Gobius to an external display from VDO, Wema, Faria or others, you should use the analogue output on the control unit together with the enclosed cable.

We recommend that you put a layer of Vaseline, which prevents oxidation, on the plugs that are connected to the control unit. The



electronics of the product are protected from damp. The sensor and the control unit do not resist water. Please contact FM Marin for advice on how to make Gobius waterproof. Furthermore, we recommend that you connect your Gobius via a 500 mA fuse.

Attaching the sensors to the tank

Start by reading through the **green** document before attaching the $\frac{3}{4}$ sensor to the tank. Please visit www.gobius.se for latest news. There you will also find our **Tank Calculator** which makes it easier for you to calculate the right level for the sensor on the tank wall.

Keep in mind that the sensor is sensitive to physical shock and therefore must be handled carefully.

Control of sensors and panel before calibrating the tank (and possible change of default settings)

Connect the Control Unit to the power source and turn the power on. Then as Gobius is starting all lamps are lit, one after another, once. (If Gobius doesn't start press the  button on the panel). After this a function control of the sensor is carried out. The red lamp will flash simultaneously with the blue lamp.

Finally the red, yellow and green lamp will show a steady light. This means that Gobius has not yet been calibrated and that you may move on to the next step.

If there should be a problem with the sensor, either with the connection or with the sensor itself, this is illustrated by the red lamp on the panel showing a steady light together with the blue lamp.

For further information, please see the "table of lights" at page 6.

You must act on this before proceeding with the installation.

If you suspect that the system does not function correctly, please contact our support service by email, support@fmmarin.se or by phone. The support service is free of charge.

Change of default settings

Gobius is made to be optimized for your unique tank and your requirements. There are differences in tank material, appropriate interval between measurings and connecting an extra gauge alternative of your choice. You will find the default settings of Gobius on page 7 of this documentation. If these are not in accordance with your requirements you will need to change them. You will find the available options in the table on page 7.

You change the settings by pressing and holding the  button on the panel. Gobius automatically flicks through the alternatives as presented in the table on page 7. Release the button when your choice is shown. Thereby you have made a new setting. Repeat this until you have made the changes you want.

1. Leave Gobius on



2. With a pen, make notes in the table on page 7 of the changes you need to do
3. Press and hold the  button until the chosen rows' colours are shown in the panel
4. Release the button to make your choice a setting
5. Repeat this until you have made the changes you want

By keeping the  button pressed until all alternatives are passed, you may flick through all alternatives without making any change of settings. A wrongly chosen setting is corrected by repeating the procedure and thus correcting the setting.

N.B!!! If you change the tank material setting, you will need to redo the calibration.

Settings control

Each and every time you turn off Gobius using the  button, your settings are presented by colour combinations on the panel according to the table on page 7. This will not happen when you turn off Gobius from an external source.

Calibration – your waste holding tank must be empty

No tanks are the same; there are always differences in e.g. size, thickness, construction and age. In order to compensate for these differences you have to calibrate the system before you start to use your Gobius. To start the calibration, start by making sure that your tank is completely empty. It is important that the boat is still and the engine turned off when calibrating the system.

Calibration during installation

1. Start by draining the tank
2. Start Gobius and wait for the red, yellow and green lights
3. Press and hold the  button until all lights are on
4. Release the button as soon as the lights are on
5. The calibration starts automatically and takes around 10 seconds
6. When the blue light is on the calibration is done, i.e. the tank is not full.

Calibration at a later date

2. When Gobius is on, press the  button and hold
3. Wait until all lights are on
4. Once the lights are on, release the button
5. The calibration starts automatically and takes around 10 seconds



6. When the blue light is on the calibration is done, i.e. the tank is not full.

Analog instrument

It is possible to plug in an analog instrument as an alternative way to show the tank level. In the table on page 7 you will find three alternatives to choose between depending on product and standard.

On page 8 you will find an illustration showing how to plug in the instrument to Gobius' control unit. The extra cable, which is enclosed in the delivery, is intended for this purpose. We assume that you have an instrument with cables already installed in your vessel and that you wish to use this with Gobius.

Extra lamp/buzzer

In addition to the Gobius panel you may want to plug in a lamp or buzzer to give a warning when the tank is $\frac{3}{4}$ full. The illustration on page 8 shows how to plug in this additional surveillance.

Finally

If possible, please finalize the installation by refilling the tank with liquid to verify that Gobius works according to your requirements.

2 different ways of turning Gobius on and off

You start Gobius by a quick push on the panel's  button or by switching on the power from an external source. A function control on the lamps and the sensor is immediately performed. When the control is done the level is measured and the correct lamp is lit.

During the measuring you may hear a soft humming sound from the sensor. Thereafter a calculation is performed in the control unit and the result is immediately presented by the lighting of the blue or red lamp.

You turn off Gobius by a quick push on the  button or by switching off the current from an external source. When Gobius is turned off it will memorize all settings and the calibration. I.e. you will not need to redo the calibration due to the power being turned off for a lengthy period of time.

Gobius technology (patented)

The sensor consists of two active parts; a shaker and an accelerator. When the shaker creates a vibration in the tank wall, the accelerator measures the size of the vibration and passes the data on to the control unit. The control unit then starts to calculate in order to give an exact estimate of whether the liquid level has passed the sensor or not.

The sensor is set to detect liquid levels through tank walls that are of different materials and thicknesses. If the tank's wall thickness is changing over time (e.g. due to possible contamination), you may need to redo the calibration according to the above instructions.

Gobius requires no extra maintenance

The Gobius system has many advantages. For instance, since the sensor is never in direct contact with liquid it will not wear out. Also, electricity



consumption is low, less than 40 mA (12 Volts).

System Illustration

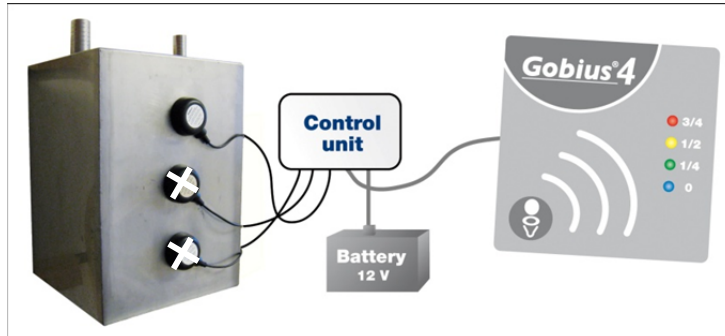

Plug from control unit to the panel



(If you connect the panel wire the wrong way the red lamp on the panel will constantly light. It will not damage the product.)

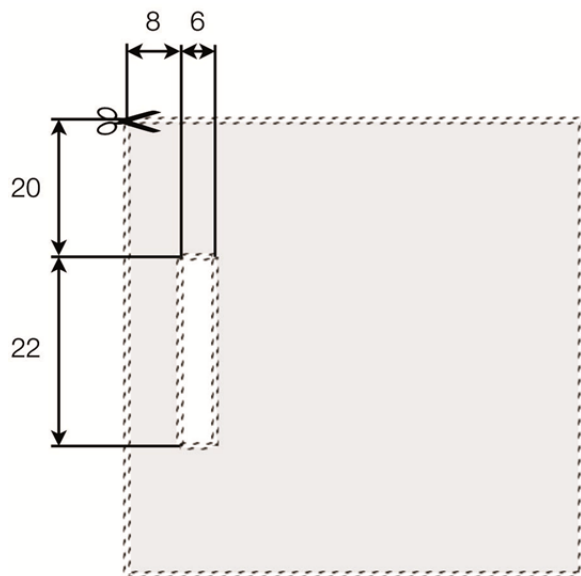

Hole template for the panel [mm]

Attaching the sensor to the tank

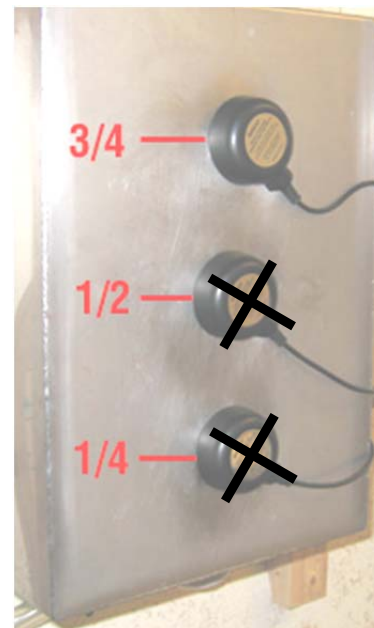



Table of lights – what the lamps on the panel show

Lamp Red	Lamp Yellow	Lamp Green	Lamp Blue	Explanation
●	●	●	○	At delivery Gobius is not yet calibrated
⊙	○	○	⊙	Test of the $\frac{3}{4}$ -sensor
○	○	○	⊙	When measuring Tank level not $\frac{3}{4}$ full
⊙	○	○	○	Tank level $\frac{3}{4}$ full
○	○	○	●	After measuring Tank is not $\frac{3}{4}$ full
●	○	○	○	Tank level $\frac{3}{4}$ full
●	○	○	●	$\frac{3}{4}$ -sensor not functioning
⊙	⊙	⊙	○	When calibrating Gobius is calibrating

● = light ○ = no light ⊙ = flashing light



Indicators in Setup Mode

Mark your choice	Lamp Red	Lamp Yellow	Lamp Green	Lamp Blue	Duration in seconds	Description
	●	●	●	●	5 s	Calibration
	○	●	○	○	5 s	Measurement period 1 minute
D	○	●	○	●	5 s	Measurement period 5 minutes
	○	●	●	○	5 s	Measurement period 10 minutes
	○	●	●	●	5 s	Measurement period 10 seconds (installation mode)
	●	○	○	○	5 s	Tank in plastic, 5 - 10 mm, fibre glass 4 - 8 mm
	●	○	○	●	5 s	Tank in plastic, 2 - 5 mm
	●	○	●	○	5 s	Tank in stainless steel 1,25 ->2 mm
D	●	○	●	●	5 s	Tank in steel 2 - 3 mm, stainless steel 2 - 3 mm, aluminum 3 - 5 mm
	●	●	○	○	5 s	Gauge 4 - 20 mA, Industrial Std
D	●	●	○	●	5 s	Gauge 10 - 180 Ω , European Std
	●	●	●	○	5 s	Gauge 240 - 33 Ω , US Std
	○	○	○	○	N/A	The setup mode will be exited without changing any parameters.

D = Default setting ● = light ○ = no light



Electrical specification

Supply Voltage:	10 ~ 29 V DC
Supply Current:	200 mA maximum (Operating)
	40 mA maximum (Idle)
Lamp driver outputs:	12/24 Volts
Max. voltage:	29 V DC
Max. current:	200 mA
Max. voltage:	29V DC

Wiring diagram for external lamp/summer

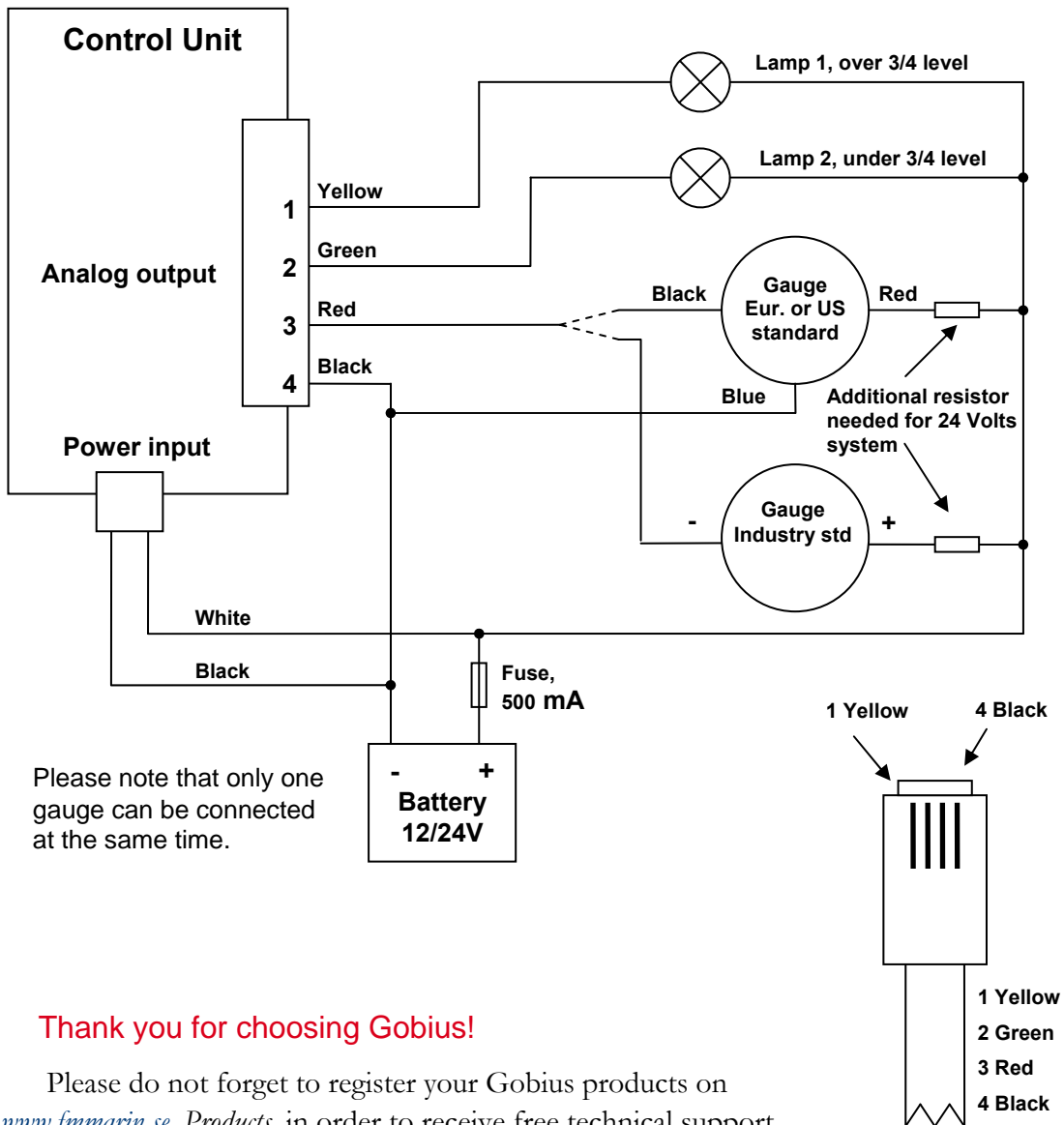

Thank you for choosing Gobius!

Please do not forget to register your Gobius products on www.fmmarine.se, Products, in order to receive free technical support